

PATENTED
216009
M266131



TEL. 1-877-687-7253



V-01~12

VICE IN ROW

Model: HRV-50, 75, 100

Adjustable vice can clamp working piece in square, round or irregular shapes. It enhances machine revolving rate and shortens time of changing molds. Saves cost.

FEATURES:

HRV-series' VICE IN-ROW is a kind of multiple clamp vice. Full set of this vice is made of Tool Steel with heat treatment more than HRC 60° of Hardness and then ground precisely to ensure durability. It enlarges clamping dimension. No matter what shape of working piece, such as square, round, cylindrical or any irregular shapes, it can be positioned quickly. Precision gear locating datum plane is adjustable so working piece can be fixed easily.

This vice is suitable for CNC Machining Centers and Surface Grinder, ...etc.

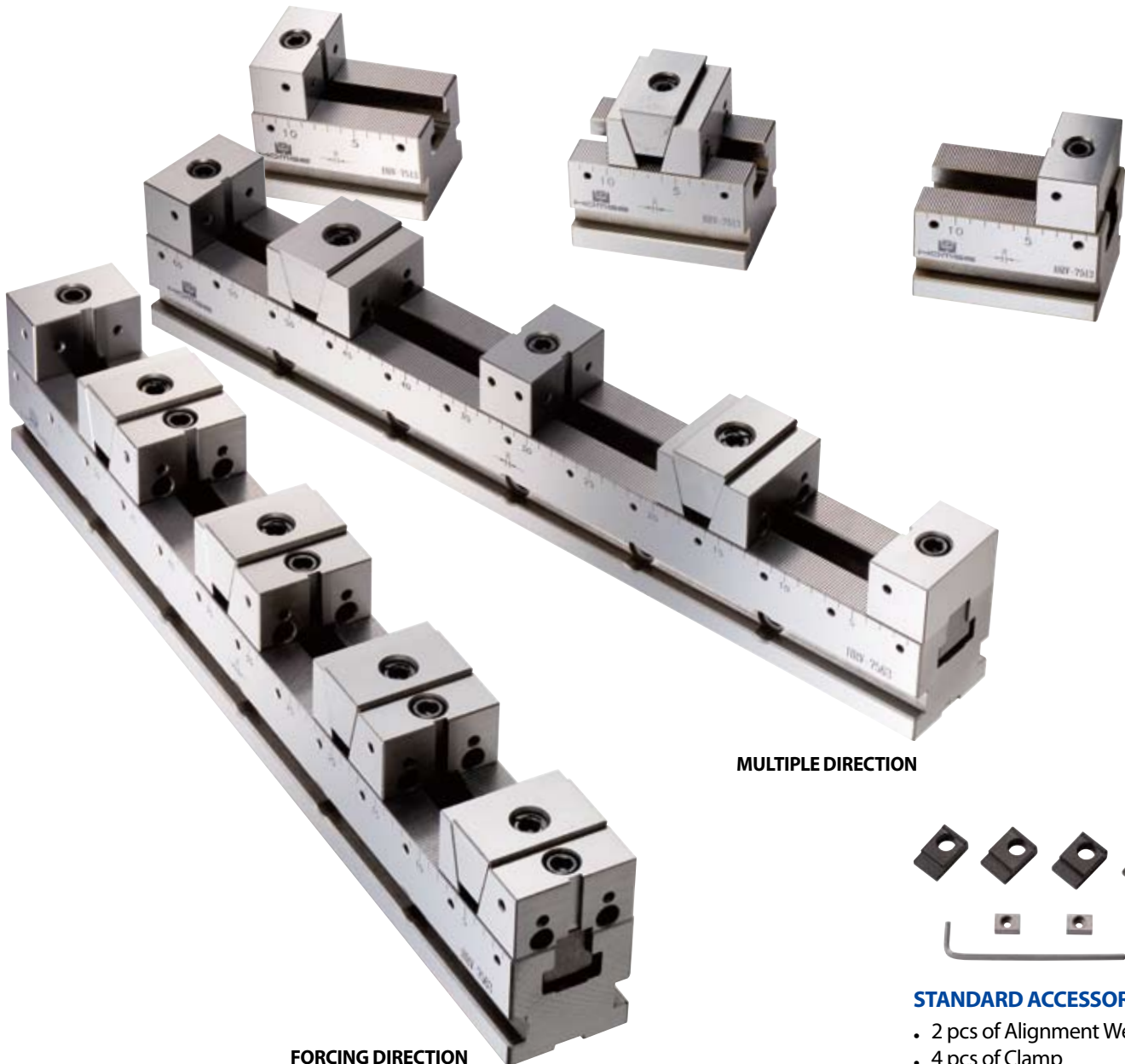

MULTIPLE DIRECTION

FORCING DIRECTION



STANDARD ACCESSORIES:

- 2 pcs of Alignment Wedge
- 4 pcs of Clamp
- 1 pc of Wrench

CLAMPING EXAMPLE

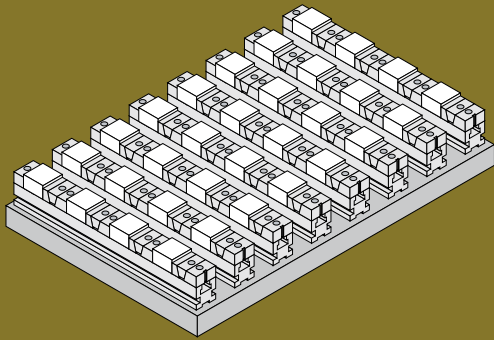

By clamping lots of rectangular small working pieces at the same time, the working table of the machine can be used completely and keep the machine operate efficiently.

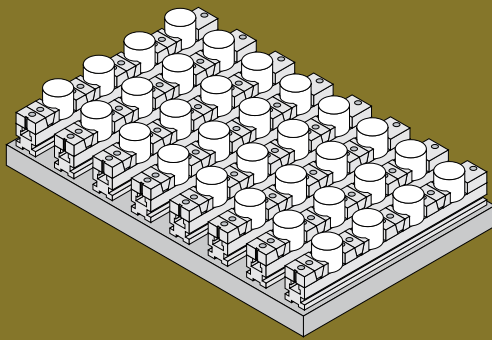

Cylindrical working pieces can be easily clamped by using optional accessory (V Jaw).

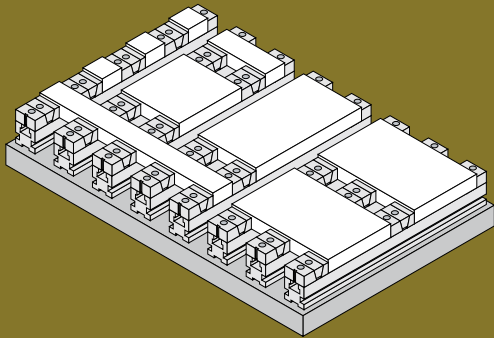

One or couple of larger working pieces can be clamped flexibly at the same time.

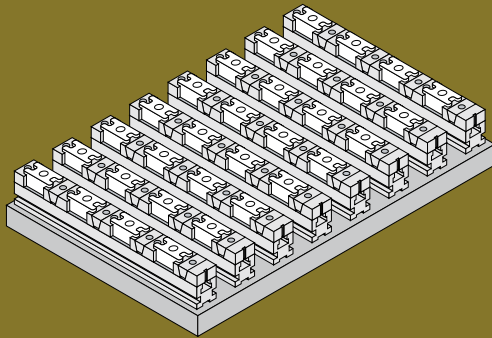

Irregular shape of working pieces can be clamped by using optional jaw which can be special tailored to meet the clamping requirement of the working pieces.



ASSEMBLED PARTS:

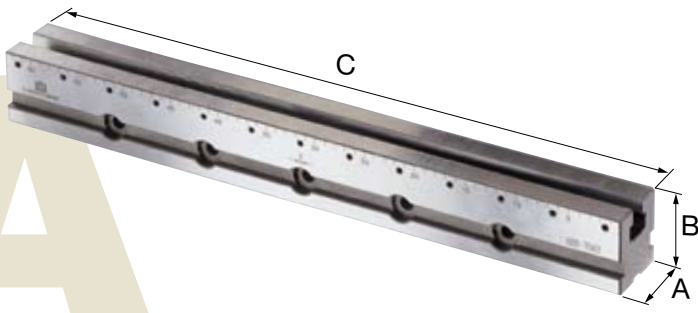

Model	A	B	C
HRV-50A30	50	50	300
HRV-50A40	50	50	400
HRV-50A50	50	50	500
HRV-50A60	50	50	600
HRV-50A70	50	50	700
HRV-75A43	75	75	430
HRV-75A53	75	75	530
HRV-75A63	75	75	630
HRV-75A73	75	75	730
HRV-100A55	100	75	550
HRV-100A65	100	75	650
HRV-100A75	100	75	750

For Forcing Direction

For Multiple Direction

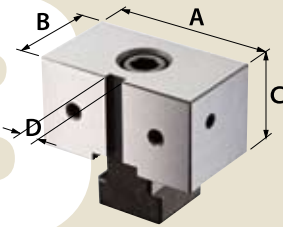

FIXED MOUTHPIECE SET

Model	A	B	C	D
HRV-50B	48	35	25	8
HRV-75B	73	42	40	8
HRV-100B	98	55	50	8

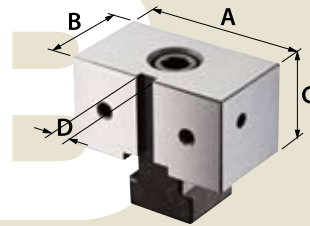

FIXED MOUTHPIECE SET

Model	A	B	C	D
HRV-50B	48	35	25	8
HRV-75B	73	42	40	8
HRV-100B	98	55	50	8

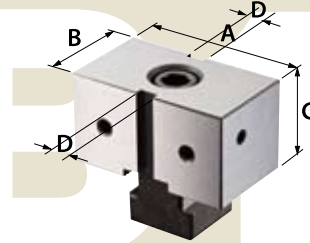

FIXED MOUTHPIECE SET

Model	A	B	C	D
HRV-50B1	48	35	25	8
HRV-75B1	73	42	40	8
HRV-100B1	98	55	50	8

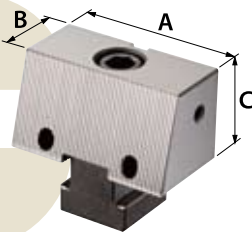

SINGLE BEVEL FIXED MOUTHPIECE SET

Model	A	B	C
HRV-50C	48	27	25
HRV-75C	73	30	40
HRV-100C	98	35	50

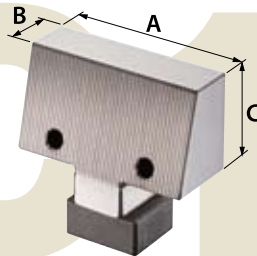

SINGLE BEVEL FIXED MOUTHPIECE SET

Model	A	B	C
HRV-50C1	48	20	25
HRV-75C1	73	20	40
HRV-100C1	98	28	50

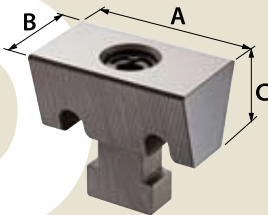

WEDGE SET

Model	A	B	C
HRV-50D	48	26	21
HRV-75D	73	42	36
HRV-100D	98	50	45

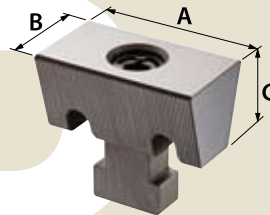

WEDGE SET

Model	A	B	C
HRV-50D	48	26	21
HRV-75D	73	42	36
HRV-100D	98	50	45

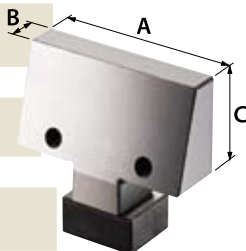

SINGLE BEVEL MOVEABLE MOUTHPIECE SET

Model	A	B	C
HRV-50E	48	13	25
HRV-75E	73	12	40
HRV-100E	98	23	50

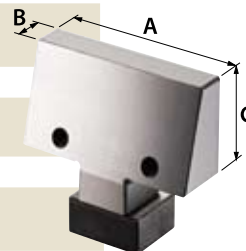

SINGLE BEVEL MOVEABLE MOUTHPIECE SET

Model	A	B	C
HRV-50E	48	13	25
HRV-75E	73	12	40
HRV-100E	98	23	50

Assembled Parts & Optional Accessories are Available for Being Ordered Separately

DIMENSION^S

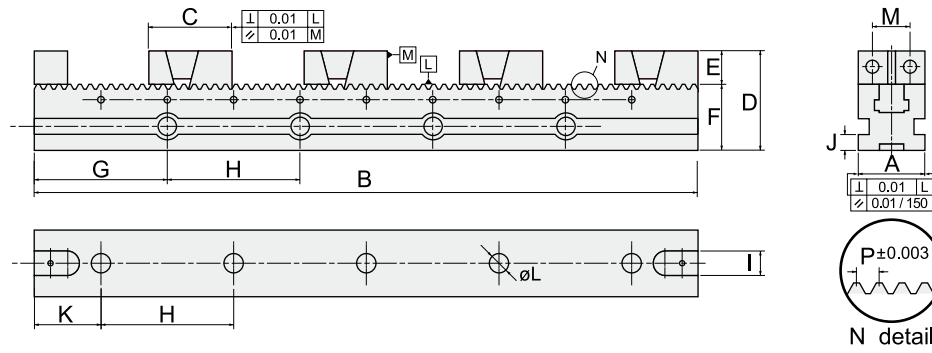

SPECIFICATIONS (Material: Tool steel. Hardness: over HRC 60°)

Unit: mm

NO	Model	A	B	C	D	E	F	G	H	I	J	K	L	M	P	KG
V-01	HRV-5030	50	300	66	75	25	50	70	80	18	10	30	14	24	1.5	7
V-02	HRV-5040		400					80				40				9
V-03	HRV-5050		500					90				50				10
V-04	HRV-5060		600					100				60				11
V-05	HRV-5070		700					110				70				12
V-06	HRV-7543	75	430	85	115	40	75	115	100	18	17	65	14	40	2	20
V-07	HRV-7553		530					115				65				25.5
V-08	HRV-7563		630					115				65				29.5
V-09	HRV-7573		730					65				115				33.5
V-10	HRV-10055	100	550	108	125	50	75	75	100	18	17	125	14	60	2.5	39.5
V-11	HRV-10065		650					125				75				44
V-12	HRV-10075		750					125				125				49

FORCING DIRECTION

Maximum range of the working pieces to be clamped

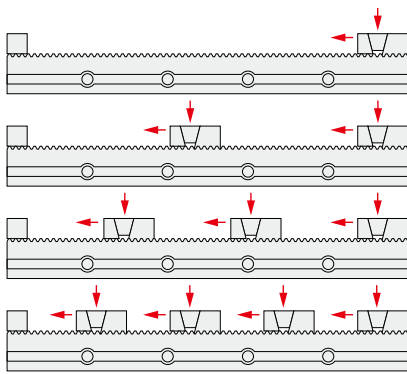

NO	Model				
V-01	HRV-5030	199	66	22	—
V-02	HRV-5040	299	116	55	25
V-03	HRV-5050	399	166	89	50
V-04	HRV-5060	499	216	122	75
V-05	HRV-5070	599	266	155	100
V-06	HRV-7543	300	109	44	—
V-07	HRV-7553	400	159	77	49
V-08	HRV-7563	500	209	111	62
V-09	HRV-7573	600	259	144	87
V-10	HRV-10055	390	142	58	—
V-11	HRV-10065	490	192	92	42
V-12	HRV-10075	590	242	125	67

MULTIPLE DIRECTION

Maximum range of the working pieces to be clamped

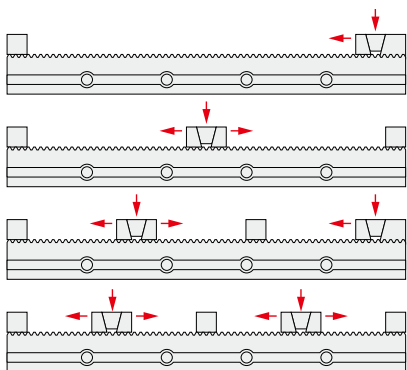

NO	Model				
V-01	HRV-5030	199	90	34	—
V-02	HRV-5040	299	140	68	43
V-03	HRV-5050	399	190	100	68
V-04	HRV-5060	499	240	134	93
V-05	HRV-5070	599	290	168	118
V-06	HRV-7543	300	130	63	51
V-07	HRV-7553	400	180	96	76
V-08	HRV-7563	500	230	129	101
V-09	HRV-7573	600	280	163	126
V-10	HRV-10055	390	170	78	45
V-11	HRV-10065	490	220	112	71
V-12	HRV-10075	590	270	145	96

HRV Adjustable Versions

Various combinations for Multiple usages

**Model: HRV-5013 (A,B,C,D,E)
HRV-7515 (A,B,C,D,E)
HRV-10018 (A,B,C,D,E)**



Model	Model	Model	Model	Model
HRV-5013-A	HRV-5013-B	HRV-5013-C	HRV-5013-D	HRV-5013-E
HRV-7515-A	HRV-7515-B	HRV-7515-C	HRV-7515-D	HRV-7515-E
HRV-10018-A	HRV-10018-B	HRV-10018-C	HRV-10018-D	HRV-10018-E

DIMENSIONS

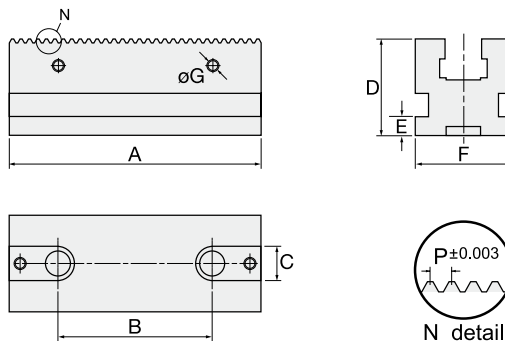

SPECIFICATIONS

Unit: mm

Model	A	B	C	D	E	F	G	P	Weight (kg)
HRV-5013	130	80	18	50	10	50	M6	1.5	2
HRV-7515	150	100	18	75	17	75	M6	2	4
HRV-10018	180	100	18	75	17	100	M6	2.5	7

OPTIONAL ACCESSORIES:



TEL. 1-877-687-7253

HOMGE

"V" JAW (FOR FIXED JAW)

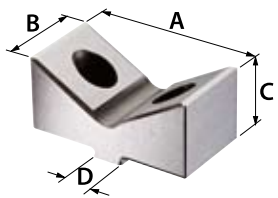

Unit: mm

Model	A	B	C	Dh7
HRV-50-VJ	48	25	21	8
HRV-75-VJ	73	40	32	8
HRV-100-VJ	98	50	44	8

FIXED SOFT JAW (FOR MOVEABLE JAW)

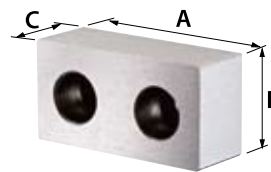

Unit: mm

Model	A	B	C
HRV-50-FMJ	48	25	16
HRV-75-FMJ	73	40	19
HRV-100-FMJ	98	50	19

MOVEABLE SOFT JAW

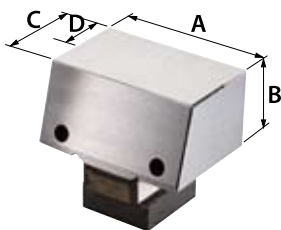

Unit: mm

Model	A	B	C	D
HRV-50-MSJ	48	25	28	20
HRV-75-MSJ	73	40	30	20
HRV-100-MSJ	98	50	29	20

FIXED SOFT JAW (FOR FIXED JAW)

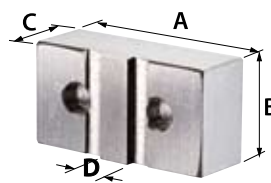

Unit: mm

Model	A	B	C	Dh7
HRV-50-FFJ	48	25	16	8
HRV-75-FFJ	73	40	19	8
HRV-100-FFJ	98	50	19	8

SUPPORTING BLOCK

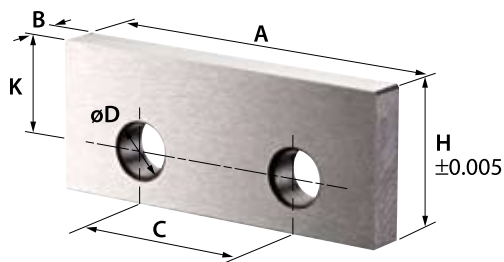

Unit: mm

Model	A	B	C	D	H	L
SB-50A	47.5	3	24	6.8	17	13
SB-50B		5			20	
SB-50C		5			22	
SB-75A	74.5	3	40	6.8	25	20
SB-75B		5			30	
SB-75C		5			35	
SB-75D		5			37	
SB-100A	97.5	5	60	6.8	35	25
SB-100B		5			40	
SB-100C		5			45	
SB-100D		5			47	

DATUM PLATE (FOR HRV-50, 75, 100)

Model: DP-A

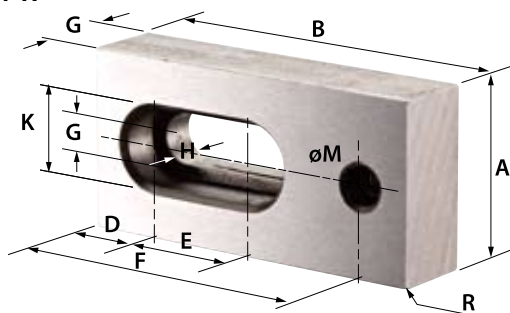

Model: DP-B

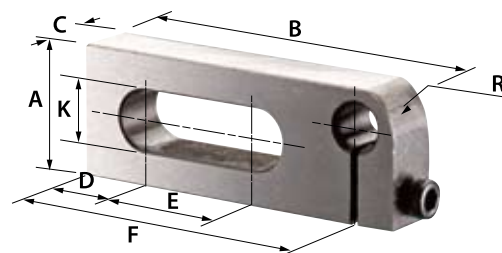

Unit: mm

Model	A	B	C	D	E	F	G	H	K	M	R
DP-A	25	50	12	10	15	43	6.5	7	11	M6	1
DP-B	19	50	9	10	15	43			11	M6	5